

Gompf

GOMPF BRACKETS, INC.
 WWW.BRACKET.COM
 sales@bracket.com

Phone: (425) 391-0495
 Fax: (425) 391-0496

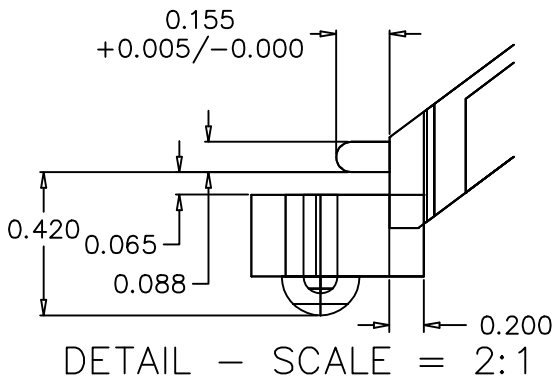

INCLUDES ONE CUSTOM
 PHILLIPS SCREW
 GOMPF PN 6089-9101
 FOR RETAINER

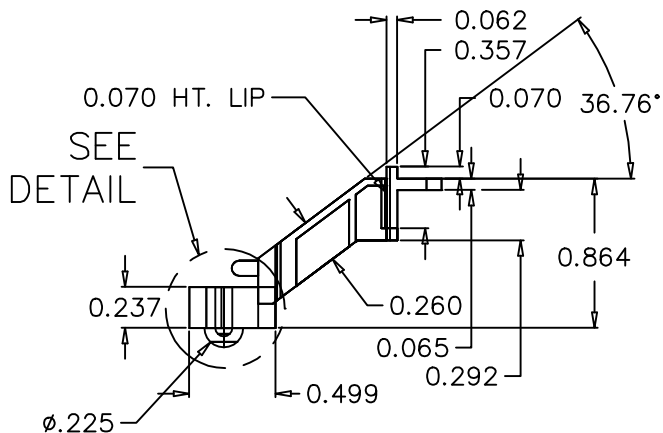

COPYRIGHT PROTECTED

DWG. NO. 9105-0000 (KIT)

MATERIAL: BLACK POLY-CARB UL94V-0

FINISH:

TOLERANCES:

STD.TOLS.+0.010
 RAD.TOLS.+0.010
 HOLE TOLS.+0.005
 MAT.TOLS.+0.002

SCALE: 1:1

DATE: 11-18-96

REV. 0

ISSUED:

APPROVALS:

DRAWN BY: NPS

